



**Town of Star Valley**  
3675 E. Highway 260  
Star Valley, Arizona 85541

**ADDENDUM #1**  
**TO THE**  
**INVITATION TO BID**  
**FOR THE**  
**ADA PARK IMPROVEMENTS PROJECT**

**Addendum #1 Date: 9/06/2024**

This addendum, and all the information contained herein and attached hereto, shall become as fully a part of the INVITATION TO SUBMIT BIDS and other BID/CONTRACT DOCUMENTS for the **TOWN OF STAR VALLEY ADA PARK IMPROVEMENTS PROJECT**, as if therein included, and shall take full and complete preference over anything therein contained to the contrary.

**Acknowledgement: Each Bidder shall acknowledge receipt of this Addendum in their bid package on the Bid Form.**

Each bidder, firm, contractor, subcontractor, or supplier shall be responsible for reading each and every item in this addendum to ascertain to what extent and in what manner it affects the work that they are interested in.

---

**RESPONSES RECEIVED TO QUESTIONS FROM PROSPECTIVE BIDDERS**

1. Question: Is the park remaining open during construction?

Response: Yes. There is one area by the pickleball court that will be blocked off, but the rest will remain open. How the open areas are closed off to keep people safe and the work zone protected is up to the contractor.

2. Question: The specs call for salvaging posts if they are salvageable. What if they aren't?

Response: The specs state that unsalvageable posts will need to be replaced. Coordinate with the town for ordering.

3. Question: Does there need to be a full-time superintendent on site at all times or are foreman's acceptable?

Response: Does not need to be the superintendent. It can be a foreman (ex: concrete foreman), but the prime Contractor is ultimately responsible.



4. Question: Are there any permit fees associated with this project from the Town? If so, what are the permit fees that need to be included in the bid price?

Response: There are no permits required therefore there are no permit fees associated with this project.

5. Question: What is meant by as-builts?

Response: If everything is built per the plans, then the as built will be the original plans. If there are any changes then the plans need to be red-lined and changes shown/documentated.

6. Question: Is there detail on the fence and gate?

Response: Yes, the manufacturer of the white posts/pickets make a 10' double swing gate to match the white vinyl fencing. Attached is an email and installation guide from the manufacturer.

7. Question: Is there a time period for construction hours?

Response: Construction may take place from dusk to dawn. Not during dark hours.

---

Attachments:

- Email
- Double Swing Gate Installation guide

\*\*\* End of Addendum #1 \*\*\*



Outlook

---

**Re: Weatherables 2-Rail Ranch Fence**

---

**From** Linda Yelder <Lyelder@weatherables.com>  
**Date** Wed 10/09/2024 11:05 AM  
**To** Dale Miller <dmliller@rickengineering.com>

The rails can be cut. The Gates go up to 8' single or 16' double

**Linda Yelder****Customer Service Representative**

**t:** 888-743-3673 | 614-295-0777  
**f:** 614-771-4806  
**w:** [weatherables.com](https://www.weatherables.com)

---

**Weatherables**, 5795 Green Pointe Dr S, Groveport, OH 43125  
[facebook](#) | [pinterest](#) | [twitter](#)

---

**From:** Dale Miller <dmliller@rickengineering.com>  
**Sent:** Wednesday, October 9, 2024 2:00 PM  
**To:** Linda Yelder <Lyelder@weatherables.com>  
**Subject:** Re: Weatherables 2-Rail Ranch Fence

Thanks, Dale

---

**From:** Linda Yelder <Lyelder@weatherables.com>  
**Sent:** Wednesday, October 9, 2024 10:59 AM  
**To:** Dale Miller <dmliller@rickengineering.com>  
**Subject:** Re: Weatherables 2-Rail Ranch Fence

3 Feet high

**Linda Yelder****Customer Service Representative**

**t:** 888-743-3673 | 614-295-0777  
**f:** 614-771-4806  
**w:** [weatherables.com](https://www.weatherables.com)

---

**Weatherables**, 5795 Green Pointe Dr S, Groveport, OH 43125

[facebook](#) | [pinterest](#) | [twitter](#)

---

**From:** Dale Miller <[dmiller@rickengineering.com](mailto:dmiller@rickengineering.com)>

**Sent:** Wednesday, October 9, 2024 1:56 PM

**To:** Linda Yelder <[Lyelder@weatherables.com](mailto:Lyelder@weatherables.com)>

**Subject:** Re: Weatherables 2-Rail Ranch Fence

Thank you. Page 2 shows the fence height may vary. Can you provide the minimum and maximum height of an installed fence? That would be appreciated.

Dale Miller

---

**From:** Linda Yelder <[Lyelder@weatherables.com](mailto:Lyelder@weatherables.com)>

**Sent:** Wednesday, October 9, 2024 10:52 AM

**To:** Dale Miller <[dmiller@rickengineering.com](mailto:dmiller@rickengineering.com)>

**Subject:** Weatherables 2-Rail Ranch Fence

This will show you the measurements: [https://www.weatherables.com/media/wysiwyg/Installation/Instructions/Fencing/Ranch/2Rail/2\\_Rail\\_Fence\\_Installation\\_Instructions\\_2024.pdf](https://www.weatherables.com/media/wysiwyg/Installation/Instructions/Fencing/Ranch/2Rail/2_Rail_Fence_Installation_Instructions_2024.pdf)

**Linda Yelder**

Customer Service Representative

**t:** 888-743-3673 | 614-295-0777

**f:** 614-771-4806

**w:** [weatherables.com](https://www.weatherables.com)

---

**Weatherables**, 5795 Green Pointe Dr S, Groveport, OH 43125

[facebook](#) | [pinterest](#) | [twitter](#)

# weatherables

2-Rail Fence

Installation Guide

## A beautiful finish that always looks new.

Thank you for choosing 2-Rail Horse Fence from Weatherables. Rest assured that your new fence will provide years of durable performance and maintenance-free satisfaction. This guide will help make your installation easy. For questions, please call 1-888-743-3673 and welcome to Weatherables.

### BOX CONTENTS

Each Fence Panel Box Includes:

- Post Cap (1)

- Post (1)

- Rails (2)

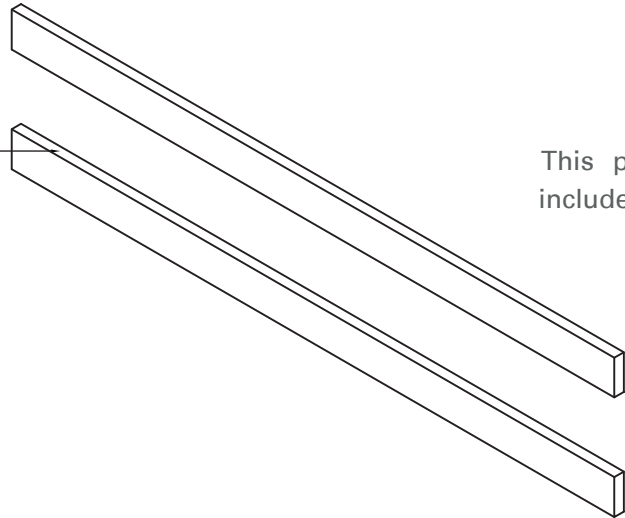

This post & cap not included (See note on left.)



### Sold Separately:

- Additional Post & Cap (1)

### PLEASE NOTE:

YOU WILL NEED TO PURCHASE ONE EXTRA POST KIT TO COMPLETE EACH OF YOUR FENCE RUNS

# Product Specifications

This fence can be trimmed down in width to accommodate custom applications

All dimensions are in inches (")

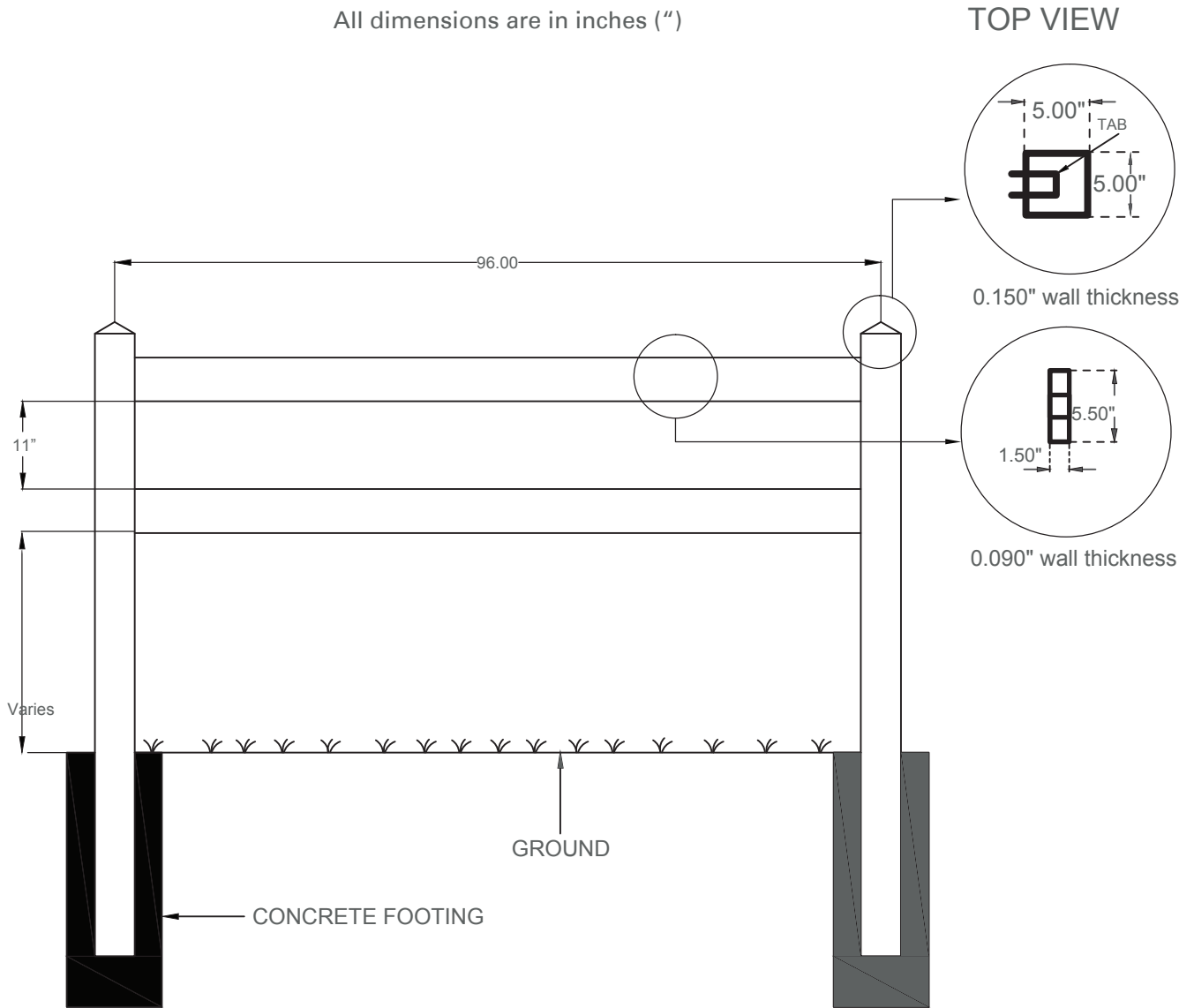

\*Check local code before installing.

## Important Reminders:

- We recommend installing 1 post and section at a time but other methods work too. Alter this method to suit your installation needs.
- Prior to construction, check with your regulatory agency for special code requirements in your area.
- Contact your utility supplier to locate and mark underground lines before excavation.
- Sketch out the layout of your fence and calculate the number of panels, gates and posts required (to finish a fence run, one extra post kit is needed).
- Careful planning and measuring of your fence is essential. Keep in mind that moving posts after the concrete sets is extremely difficult.



**Fast2k Tip! Wherever concrete is used in installation, use Fast2K instead to simplify the process. Fast2K is a concrete alternative that is much easier to use and set.**

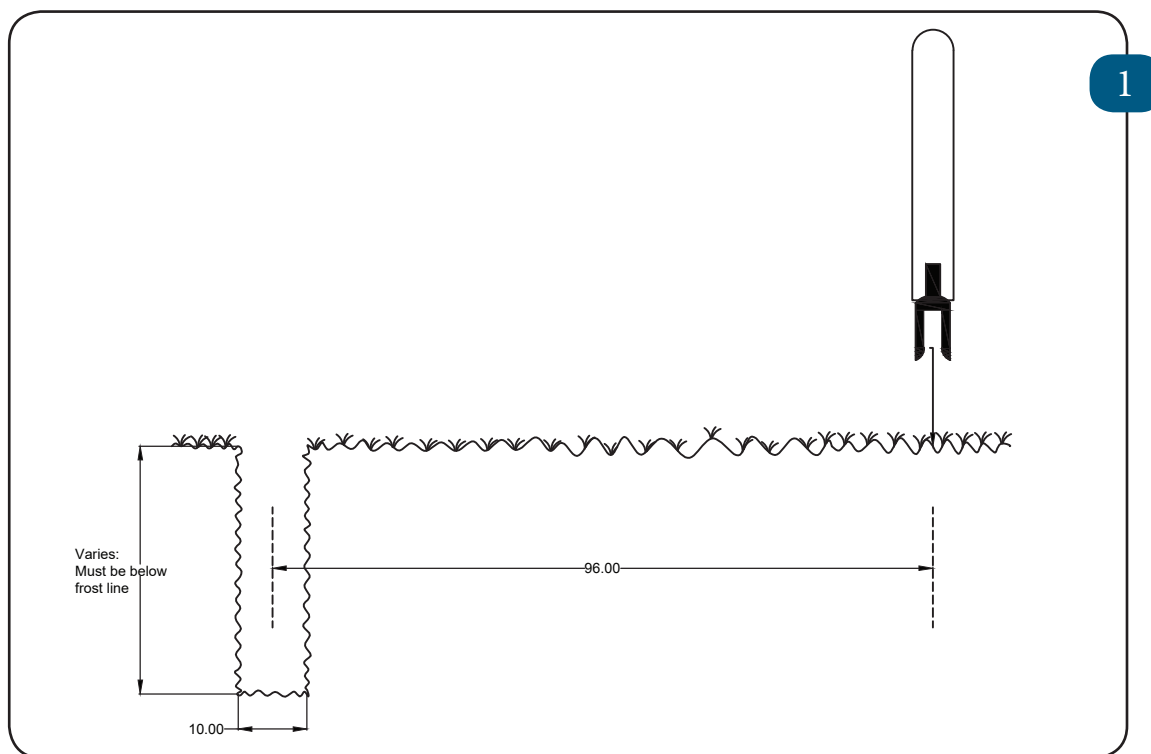

1. String your fence line and begin by digging your first post hole: 10" -12" wide x 32" -36" deep.



**Fast2K Tip! For Fast2k install, dig hole 6" wide x 32" deep.**

2. Dig your second hole 96" on center to your first hole, your third hole 96" on center to your second hole, and so on. Be sure to dig only 3-4 holes at a time to ensure proper spacing.



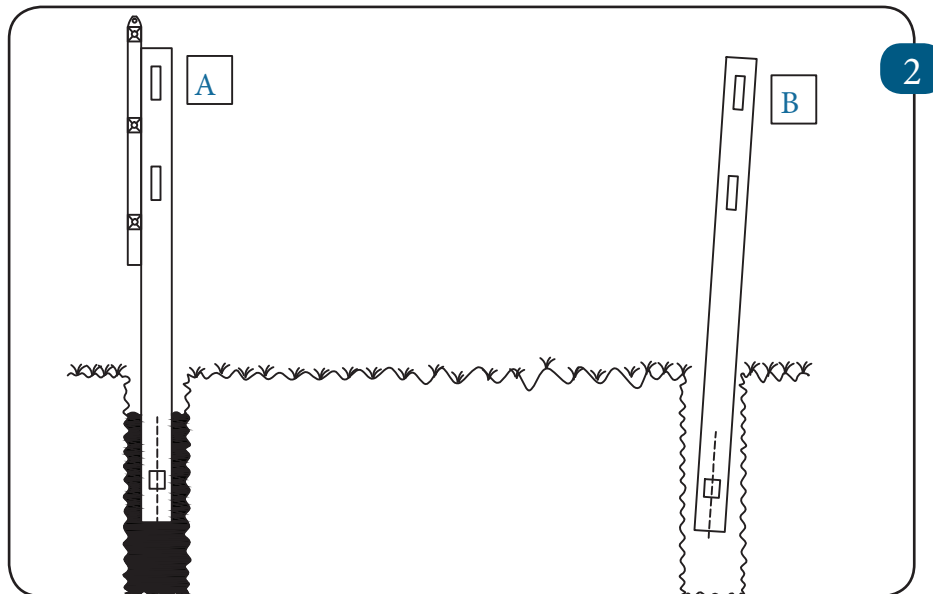

1. Insert post A into hole and set concrete. Post B may be loosely laying in hole until panel is fully installed. Repeat process down the line.

**!** **Fast2K Tip! Add one 12.4 oz. bag to the hole. Hold post in place to prevent movement and follow mixing instructions on the bag. Pour around post and plumb during expansion.**

2. To set posts in concrete, hold post in place and prevent movement to ensure the post stays straight. Be prepared to use a minimum of (1) 60lb. bag of concrete for each post hole.
3. Mix concrete and pour wet.
4. Pour concrete in hole and plumb. Fill any remaining space with soil. Lastly, verify the spacing between the ground and the bottom rail is correct (up to 11").

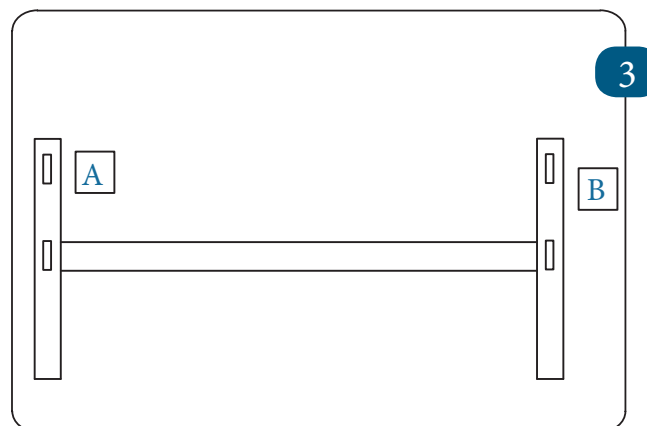

1. Insert rails into post A and then into post B.

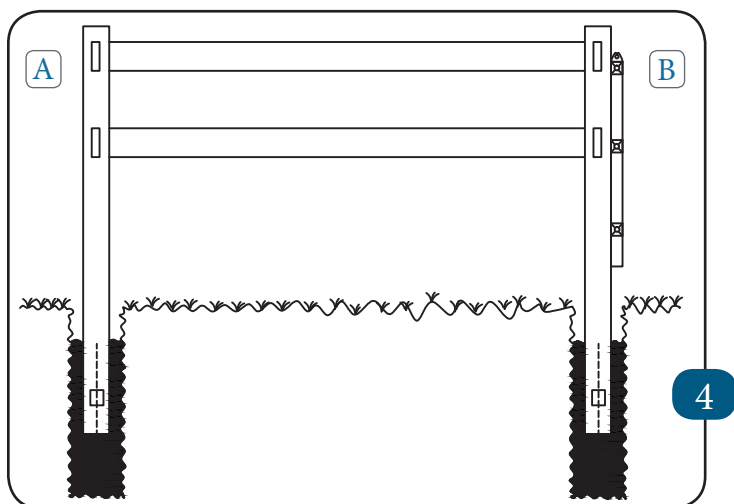

1. Straighten and level post B.
2. Pour in mixed concrete.
3. Insert post hole covers into unused holes of first post. Repeat steps down the line.

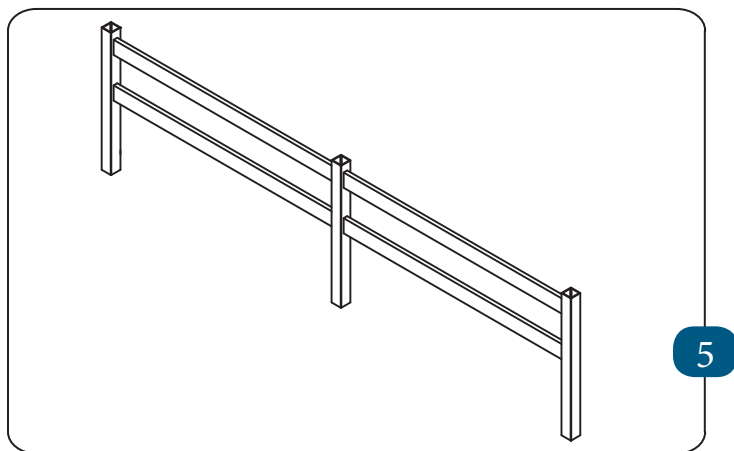

If more material is needed, please call  
1-888-743-3673.